



NOW PART OF HARMONIC



### BENEFITS

- Broadcast-class reliability
- 100% Spectrum compatibility
- Robust, well-proven architecture
- Compact physical size

### Find More Online

[www.omneon.com/MediaDeck](http://www.omneon.com/MediaDeck)

## Omneon MediaDeck™ Integrated Media Server

The Omneon MediaDeck™ integrated media server delivers the broadcast quality and mission-critical reliability of the world's leading transmission server in a convenient and cost-effective package. Omneon MediaDeck packs up to six video channels, Gigabit Ethernet connectivity and dual-parity RAID storage into a compact 2 RU chassis. With MediaDeck, even the smallest broadcast and programming operations can implement server-based ingest and playout operations or sophisticated file-based workflows in a broad range of video formats. By leveraging the Omneon Spectrum architecture, MediaDeck is immediately deployable with Omneon MediaTools productivity software for ingest, playout, and delay serving, and with over a hundred third-party automation and production applications.

### Built for Broadcast

Like the Spectrum line of media servers, Omneon MediaDeck is optimized to satisfy the demanding reliability and performance requirements of broadcast operations. Unlike media servers that rely on PC computing platforms and operating systems such as Windows, the Omneon MediaDeck system is engineered to satisfy the highly focused needs of the broadcast industry, rather than general-purpose computing. For example, the operating system resides in flash memory ensuring rapid boot up and eliminating the risks associated with system drive failures.

Omneon MediaDeck includes eight hot-swappable enterprise-class SATA disk drives for content storage. The use of dual-parity RAID ensures that the system continues to operate even in the event of simultaneous failure of any two disk drives. Video I/O modules and redundant power supplies can be hot-swapped for uninterrupted operation.

### Cost-effective

Omneon MediaDeck supports up to six channels of standard-definition video I/O at up to 50 Mbps, or up to four channels of high-definition video I/O at up to 100 Mbps, while at the same time handling IP-based file transfer traffic in and out of the system. By delivering this high level of performance in a fully integrated system, Omneon MediaDeck establishes a new price-per-channel benchmark for professional grade multi-channel media servers.

### Drop-in Compatibility

Omneon MediaDeck uses the same time-proven, robust code base as Omneon Spectrum media servers. Thus, it works out of the box with all applications supported by Spectrum systems, including automation, editors, archiving systems, Omneon MediaTools and others.

Omneon MediaDeck Gigabit Ethernet connectivity is a standard implementation of high-speed Ethernet for asynchronous file transfer and support of FTP, SMB and the Apple® Filing Protocol, providing simple, standardized file movement techniques.

### Video Format Flexibility

Omneon MediaDeck provides mounting space and power for up to two independent I/O modules, which provide video encoding and decoding. Omneon MediaDeck I/O modules currently include a three-channel SD unit and any of several types of HD/SD two-channel units. The system supports any combination of I/O modules for maximum flexibility, including mixing HD and SD modules in the same MediaDeck.

## PRODUCT OVERVIEW

### Omneon MediaDeck Configured With Dual I/O Modules

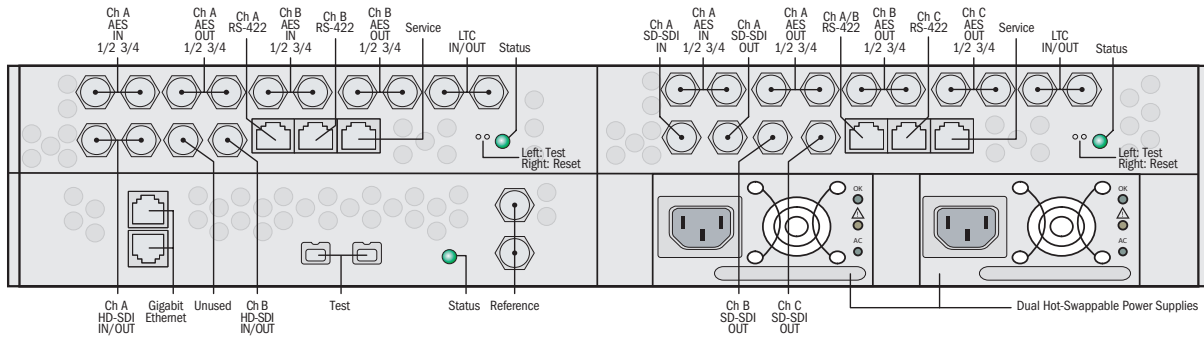

### Omneon MediaDeck Specifications

Model	Features
<b>Omneon MediaDeck Core System</b>	<p><b>Network:</b> Two Gigabit Ethernet ports. The File Communications port is used for file transfers into and out of Omneon MediaDeck using FTP, SAMBA and AFP protocols. The Control port is used for control functions, such as RPC-based accesses from the Omneon SystemManager application or Player API.</p> <p><b>Power:</b> Dual, redundant hot-swappable power supplies: Under 400 watts total with two Omneon MediaDeck video I/O modules, 100-240 V, 50-60 Hz.</p> <p><b>Processing:</b> Dual processors to handle IP and realtime video loads simultaneously.</p>
<b>Storage</b>	<ul style="list-style-type: none"> <li>Using 500 GB disk drives, Omneon MediaDeck provides 3 TB of content storage</li> <li>Using 1 TB disk drives, 6 TB of content storage is available</li> <li>Dual Parity RAID guarantees continued operation even if two disks fail simultaneously</li> <li>Disks can be hot-swapped, allowing continued operation while being repaired</li> </ul>
<b>MPEG-2 HD/SD I/O Module</b>	<p><b>High and Standard Definition Support with the HD/SD Module:</b></p> <ul style="list-style-type: none"> <li>Up to two HD/SD modules per system; each includes: <ul style="list-style-type: none"> <li>Two video channels, both of which can either play or record. Both are independently configurable for HD or SD SDI video I/O according to SMPTE 292M/259M.</li> <li>16 channels of embedded audio, or up to four channels of discrete (AES/EBU) audio.</li> <li>MPEG-2 play and record at a variety of operating points: <ul style="list-style-type: none"> <li>Long GOP at up to 85 Mbps</li> <li>I-Frame at up to 100 Mbps</li> <li>User-selectable MXF OP1a (self-contained essence), MXF OP1b (referenced essence) or QuickTime (self-contained or reference) wrapper.</li> </ul> </li> <li>Includes simultaneous creation of low-resolution proxy during recording</li> <li>Supports scrub audio during offspeed play</li> </ul> </li> <li>A lower-priced SD-only version of this module is also available; it can later be field-upgraded to the full feature set of the HD/SD module.</li> </ul>
<b>MPEG-2/DV HD/SD Playback Module with up/down conversion and simulcast</b>	<p><b>Up- and Down-Conversion Support with the HD/SD Playback Module</b></p> <ul style="list-style-type: none"> <li>One or two HD/SD playback modules per system; each includes: <ul style="list-style-type: none"> <li>Two playback channels, individually configurable for either SD or HD output</li> <li>HD and SD clips may be freely mixed on each playback timeline: material is converted as needed for the output format selected</li> <li>Can play a single mixed SD/HD timeline, generating both an all-HD output and an all-SD output in frame-accurate synchronization, commonly called "simulcast"</li> <li>Clips can be either MPEG-2 at the same operating points as the HD I/O Module described above or DV/DVCPRO/DVCPRO HD, freely intermixed on the timeline</li> <li>Supports scrub audio during off-speed play</li> </ul> </li> </ul>
<b>AVC-Intra HD I/O Module</b>	<p><b>AVC-Intra Support with the AVC-Intra HD I/O Module:</b></p> <ul style="list-style-type: none"> <li>Each module offers: <ul style="list-style-type: none"> <li>Two play/record video channels individually configurable for Class 50 or Class 100 operation</li> <li>16 channels of embedded audio, or up to four channels of discrete (AES/EBU) audio</li> <li>Includes simultaneous creation of low-resolution proxy during recording</li> <li>Supports scrub audio during offspeed play</li> </ul> </li> </ul>
<b>SD I/O Module</b>	<p><b>Standard Definition Support With SD Module:</b></p> <ul style="list-style-type: none"> <li>Up to two SD modules per system; each includes: <ul style="list-style-type: none"> <li>Three video channels, one of which can either play or record, the other two being play only.</li> <li>16 channels of embedded audio, or up to four channels of discrete (AES/EBU) audio.</li> <li>Play and record of the following video formats: <ul style="list-style-type: none"> <li>DV</li> <li>DVCPRO 25 and 50</li> <li>MPEG-2 ranging from 3 to 50 Mbps</li> <li>IMX encoding at 30, 40, and 50 Mbps</li> <li>Back-to-back playout of DV and MPEG-2 clips</li> </ul> </li> </ul> </li> </ul>



**U.S. Headquarters:**  
1237 E. Arques Ave.  
Sunnyvale, CA 94085  
ph +1 866.861.5690  
ph +1 408.585.5000  
fx +1 408.585.5099

**Europe:**  
5 Lindenwood  
Chineham, Basingstoke  
RG24 8QY United Kingdom  
ph +44 1256.347.400  
fx +44 1256.347.410

**Japan:**  
Ginza 3-Chome Bldg. 8F  
3-14-1 Ginza, Chuo-ku  
Tokyo 104-0061 Japan  
ph +81 03.5565.6735  
fx +81 03.5565.6736

**Asia/Pacific:**  
20 Loyang Crescent  
Singapore 508984  
ph +65 6548.0500  
fx +65 6548.0504

